

STR83145 AND STR84145

LATCHED, UNIVERSAL INPUT-VOLTAGE SWITCHES

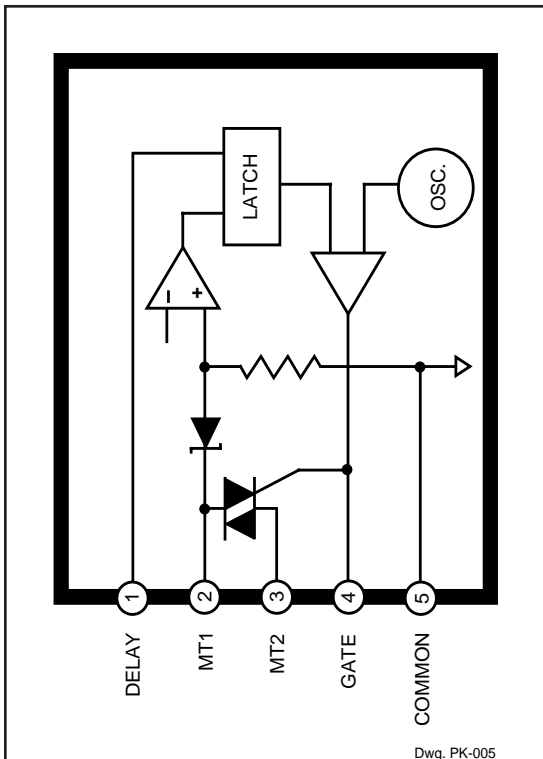

ABSOLUTE MAXIMUM RATINGS

Repetitive Peak OFF-State Voltage, V_{DRM}	500 V
Static ON-State Current, $I_{T(RMS)}$	
STR83145	10 A
STR84145	12 A
Non-Repetitive Surge ON-State Current, I_{TSM}	
STR83145	100 A
STR84145	120 A
Package Power Dissipation, P_D	See Graph
Triac Junction Temperature, T_J	+125°C
Frame Temperature, T_M	+100°C
Operating Temperature Range, T_A	-20°C to +125°C
Storage Temperature Range, T_{stg}	-40°C to +125°C

Intended for power supplies with universal inputs (85 V to 265 V rms), the STR83145 and STR84145 latchable, universal input-voltage switches incorporate timing, control, and drive circuitry with a high-current triac (bidirectional triode thyristor) switch. Each device senses the applied ac line potential and automatically switches the rectifier and associated capacitors between a voltage-doubler configuration (for line voltages to 141 V) and a full-bridge configuration (for line voltages greater than 149 V). This eliminates the possibility of user error with adjustable jumpers or switches. Also, the related switch-mode power stage need operate only over a reduced range of dc input voltages when compared with "wide input" power supplies using a bridge rectifier only. The reduction in dc input voltage range permits the use of lower-voltage capacitors and leads to a reduction in power stage stresses and power dissipation. The STR83145 and STR84145 differ only in their maximum ac current rating (10 A and 12 A, respectively).

The internal sensitive-gate triac is switched by a temperature-compensated constant-current gate driver driven by a 15 kHz pulse train to reduce power dissipation. The switch-over voltage is accurately set during manufacture for consistent operation. An user-adjustable delay is provided to ensure start-up in the full-bridge mode. Once established (by an input voltage greater than 149 V rms), an integral latch holds the full-bridge mode to preclude false application of the doubler mode during brownouts, voltage droops, or missing cycles.

The requirements of low transient thermal impedance and steady-state thermal resistance are satisfied in a molded, 5-lead single in-line power package. Similar input-voltage switches, with a switch point of 159 V rms, are also available.

FEATURES

- Low Duty Cycle Triac Drive for Minimum Dissipation
- For Universal Input Operation Between 85 V rms and 265 V rms to 10 A or 12 A
- Internal Latch Prevents False Mode Switching
- Internal Sensitive-Gate Power Triac
- Adjustable Start-Up Delay
- Accurate 145 V rms Switch-Point Voltage
- Low External Parts Count
- Low Power Dissipation
- Low-Power External Parts

Always order by complete part number:

Part Number	Max. On-State Current
STR83145	10 A rms
STR84145	12 A rms