

## MAGNETICS KOOL M $\mu$ <sup>®</sup> E-CORES

### Introduction

Kool M $\mu$ <sup>®</sup> powder cores are made of a ferrous alloy powder, which has low losses at elevated temperatures. Kool M $\mu$  E-cores have a distributed air gap which makes them ideally suited for switching regulator inductors, flyback transformers, and power factor correction (PFC) inductors. The 10,500 gauss saturation level of Kool M $\mu$  provides a higher energy storage capability than can be obtained with gapped ferrite E-cores, resulting in smaller core size. Kool M $\mu$  E-cores are competitively priced against gapped ferrite E-cores and their distributed air gap eliminates gap loss problems associated with ferrites. Kool M $\mu$  E-cores have significantly lower losses and substantially better thermal properties when compared to powdered iron E-cores.

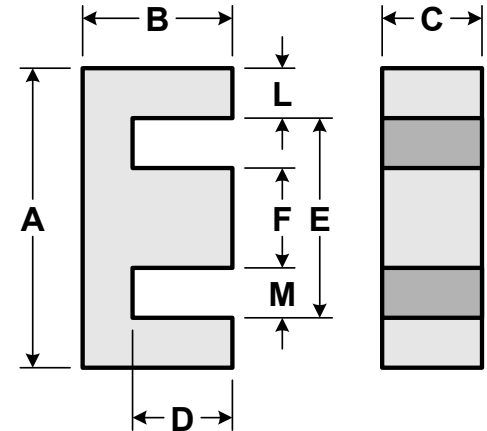

Figure 1

Table 1

PART NO.		A	B	C	D (min)	E (min)	F	L (nom)	M (min)
00K1207E (EF 12.6)	in (mm)	0.500±.010 (12.7)	0.252±.004 (6.4)	0.140±.006 (3.6)	0.178 (4.4)	0.350 (8.9)	0.140±.005 (3.6)	0.070 (1.8)	0.104 (2.6)
00K1808E (EI-187)	in (mm)	0.760±.012 (19.3)	0.319±.007 (8.1)	0.188±.006 (4.8)	0.218 (5.5)	0.548 (13.9)	0.188±.005 (4.8)	0.094 (2.4)	0.183 (4.6)
00K2510E (E-2425)	in (mm)	1.000±.015 (25.4)	0.375±.007 (9.5)	0.250±.004 (6.5)	0.245 (6.2)	0.740 (18.8)	0.250±.005 (6.2)	0.125 (3.2)	0.246 (6.3)
00K3007-E (DIN 30/7)	in (mm)	1.185±.018 (30.1)	0.591±.009 (15)	0.278±.006 (7.1)	0.376 (9.7)	0.768 (19.5)	0.274±.008 (6.9)	0.201 (5.1)	0.254 (6.5)
00K3515E (EI-375)	in (mm)	1.360±.020 (34.5)	0.557±.009 (14.1)	0.368±.007 (9.4)	0.378 (9.6)	0.995 (25.3)	0.367±.008 (9.3)	0.175 (4.4)	0.310 (7.9)
00K4017E (EE 42/11)	in (mm)	1.687±.025 (42.8)	0.830±.013 (21.1)	0.424±.010 (10.8)	0.587 (15)	1.195 (30.4)	0.468±.010 (11.9)	0.234 (5.9)	0.365 (9.3)
00K4020E (DIN 42/15)	in (mm)	1.687±.025 (42.8)	0.830±.013 (21.1)	0.608±.010 (15.4)	0.587 (15)	1.195 (30.4)	0.468±.010 (11.9)	0.234 (5.9)	0.365 (9.3)
00K4022E (DIN 42/20)	in (mm)	1.687±.025 (42.8)	0.830±.013 (21.1)	0.788±.010 (20)	0.587 (15)	1.195 (30.4)	0.468±.010 (11.9)	0.234 (5.6)	0.365 (9.3)
00K4317E (EI-21)	in (mm)	1.609±.024 (40.9)	0.650±.011 (16.5)	0.493±.007 (12.5)	0.409 (10.4)	1.115 (28.3)	0.493±.008 (12.5)	0.238 (6)	0.310 (7.9)
00K5528E (DIN 55/21)	in (mm)	2.16±.032 (54.9)	1.085±.016 (27.6)	0.812±.015 (20.6)	0.729 (18.5)	1.476 (37.5)	0.660±.015 (16.8)	0.330 (8.4)	0.405 (10.3)
00K5530E (DIN 55/25)	in (mm)	2.16±.032 (54.9)	1.085±.016 (27.6)	0.969±.015 (24.6)	0.729 (18.5)	1.476 (37.5)	0.660±.015 (16.8)	0.330 (8.4)	0.405 (10.3)
00K6527E (Metric E65)	in (mm)	2.563±.050 (65.1)	1.279±.150 (32.5)	1.063±.016 (27)	0.874 (22.2)	1.740 (44.2)	0.775±.012 (19.7)	0.394 (10)	0.476 (12.1)
00K7228E (F11)	in (mm)	2.850±.043 (72.4)	1.100±.020 (27.9)	0.750±.015 (19.1)	.699 (17.8)	2.072 (52.6)	0.750±.015 (19.1)	0.375 (9.5)	0.665 (16.9)
00K8020E (Metric E80)	in (mm)	3.150±.047 (80)	1.500±.025 (38.1)	0.780±.015 (19.8)	1.103 (28.1)	2.334 (59.3)	0.780±.015 (19.8)	0.390 (9.9)	0.780 (19.8)