



STK25CA8

128K x 8 *AutoStore*[™] nvSRAM

QuantumTrap[™] CMOS

Nonvolatile Static RAM Module

FEATURES

- Nonvolatile Storage without Battery Problems
- Directly Replaces 128K x 8 Static RAM, Battery-Backed RAM or EEPROM
- 35ns and 45ns Access Times
- *STORE* to EEPROM Initiated by *AutoStore*[™] on Power Down
- *RECALL* to SRAM on Power Restore
- 22mA I_{CC} at 200ns Cycle Time
- Unlimited READ, WRITE and *RECALL* Cycles
- 1,000,000 *STORE* Cycles to EEPROM
- 100-Year Data Retention Over Full Commercial Temperature Range
- Commercial and Industrial Temperatures
- 32-Pin 600 mil Dual In-Line Module

DESCRIPTION

The Simtek STK25CA8 is a fast static RAM with a nonvolatile, electrically erasable PROM element incorporated in each static memory cell. The SRAM can be read and written an unlimited number of times, while independent nonvolatile data resides in the EEPROM. Data transfers from the SRAM to the EEPROM (the *STORE* operation) can take place automatically on power down using charge stored in system capacitance. Transfers from the EEPROM to the SRAM (the *RECALL* operation) take place automatically on restoration of power.

BLOCK DIAGRAM

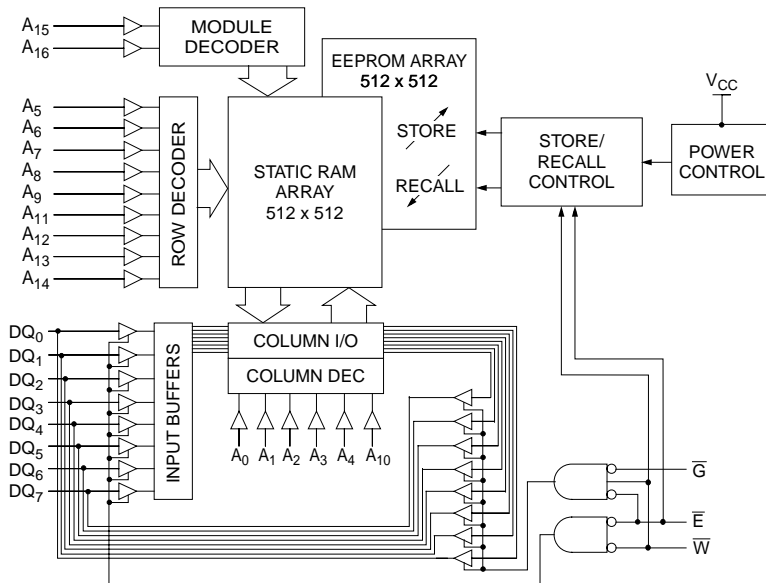

PIN CONFIGURATIONS

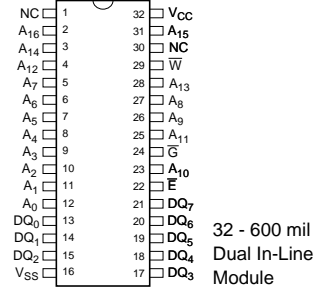

PIN NAMES

A ₀ - A ₁₆	Address Inputs
\bar{W}	Write Enable
DQ ₀ - DQ ₇	Data In/Out
\bar{E}	Chip Enable
\bar{G}	Output Enable
V _{CC}	Power (+ 5V)
V _{SS}	Ground